

## Premium ES spindles

**E**nergy is a major cost factor in spinning that eats away the profits of spinning mills. Hence, **energy saving, without compromising productivity and quality, is a top priority for spinning mills.**

TeraSpin Premium ES spindles are the best solution to reduce spinning energy cost. These spindles, which are available with HF1/HF100 spindle bearing units with 18 mm wharve diameter are specifically designed to reduce energy consumption significantly. The well proven, strong, and sturdy design of HF1/HF100 spindle bearing units make the spindles suitable for both manual and auto doffing machines.

Spindles are available with different design combinations:

- Aluminium plug type
- For manual doffing ring frames
- For auto-doffing ring frames
  - with knurling and cutters
- Suitable for 4-spindle tape drives
- Equipped with
  - self-locking inserts or external locking hooks
  - spring type buttons or centrifugal type buttons

HF 100	For spindle speeds of up to 25,000* rpm (mechanical)
HF 1	For spindle speeds of up to 22,000* rpm (mechanical)

*\*when used under the right conditions*



### Features

- Wharve diameter: 18 mm minimum
- High level of manufacturing precision for all spindle components
- Only two-point contact (at footstep and neck bearing)
- Compact neck bearing manufactured with higher precision
- Optimised damping of spindle vibrations with improved design and German components
- Well proven conical footstep design manufactured with higher precision
- Spring support for axial load

### Benefits

- Low vibrations
- Low noise level
- Long life
- Significantly lower energy consumption

# Spindle bearing unit specifications for Premium series spindles

All dimensions are in mm

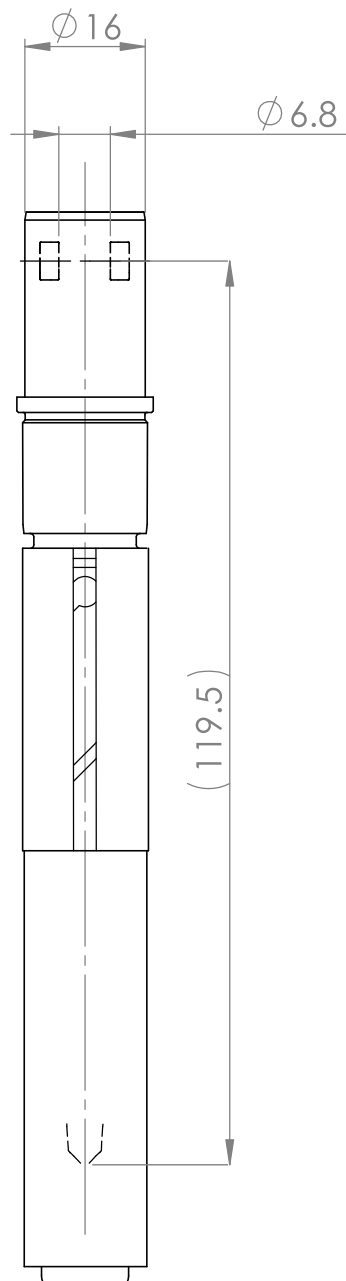

**HF1**  
For speeds up to 22000\* rpm

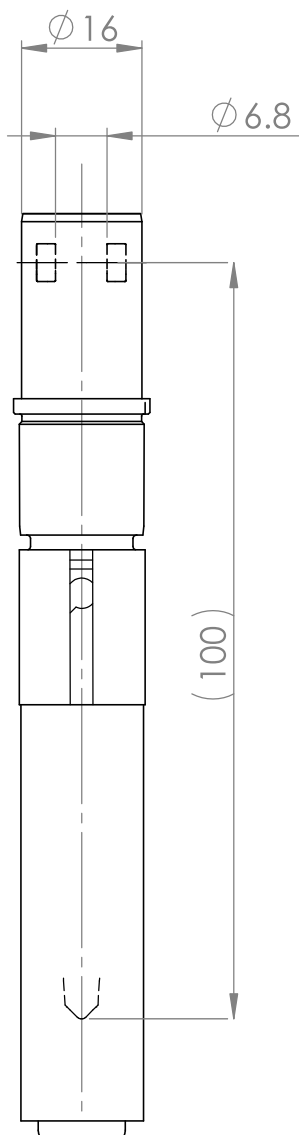

**HF100**  
For speeds up to 25000\* rpm

\* When used under the right condition

Manufactured by:



**A.T.E. ENTERPRISES PRIVATE LIMITED**

(Business Unit: TeraSpin)

T: +91-2717-699061 E: sales@teraspin.com

W: www.teraspin.com

Marketed and sold by:



**A.T.E. ENTERPRISES PRIVATE LIMITED**

T: +91-22-6676 6100 E: poacc@ateindia.com

W: www.ategroup.com

